

 Splice or tee connection kit

The T-100 is an above-insulation splice or tee kit, designed for use with up to three Raychem BTV, QTVR, XTV, KTV or VPL industrial parallel heating cables. It is approved for use in hazardous locations.

The rugged stand protects the heating cable and allows for up to 100 mm (4") of thermal insulation. The core sealing boot does not require a heat gun or torch for the installation (no hot work permit necessary).

The non-curing sealant (silicone free) in the boot allows easy installation and facilitates maintenance. Compared to existing systems, the T-100 significantly reduces installation and maintenance time and effort.

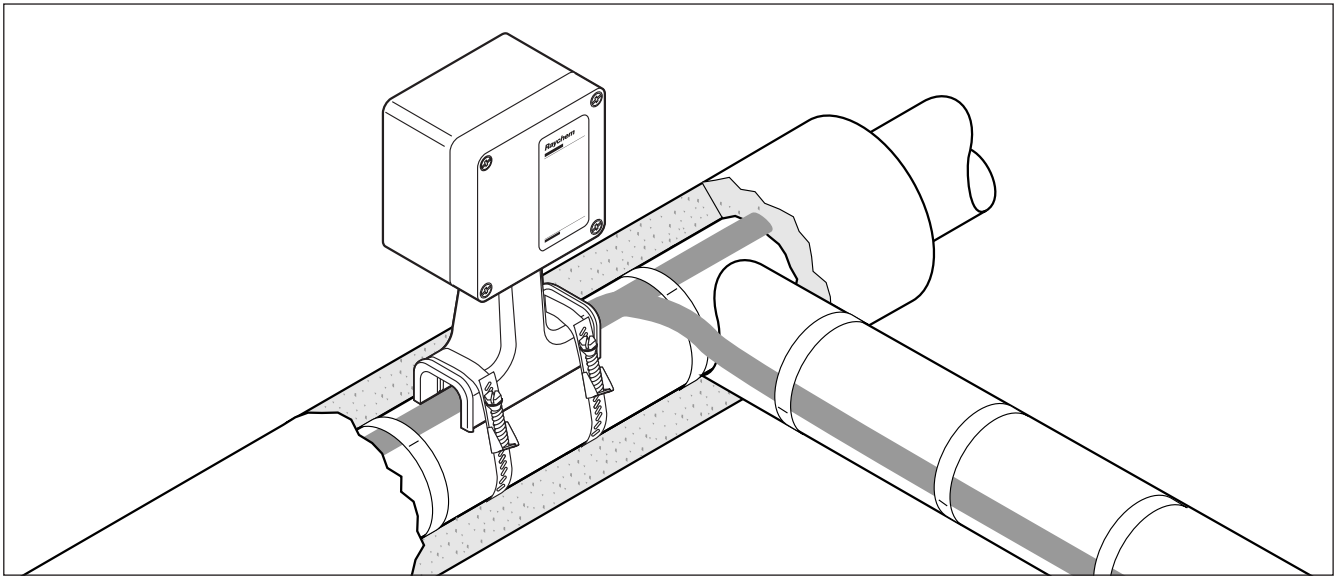

**Description**

This kit is an above-insulation splice/tee, appropriate for use worldwide with no requirements for local customization.

**Kit contents**

- 1 splice/tee enclosure and lid
- 1 stand assembly
- 3 core sealers
- 3 green/yellow earthing sleeve
- 3 compression crimps
- 3 crimping insulating tubes
- 1 polywater sachet
- 1 spanner
- 1 strain relief assembly
- 2 grommet plugs
- 1 installation instruction

**Approvals**

Hazardous locations



Class I, Div. 2, Groups A, B, C, D  
Class II, Div. 1 & 2, Groups E, F, G  
Class III



Class I, Zone 1, AEx e IIC



II 2 G/D EEx e II IP 66  
PTB 98 ATEX 1020 U

DNV approval  
DNV Certificates No. E-5121 and  
No. E-5122

**Dimensions (in mm)**

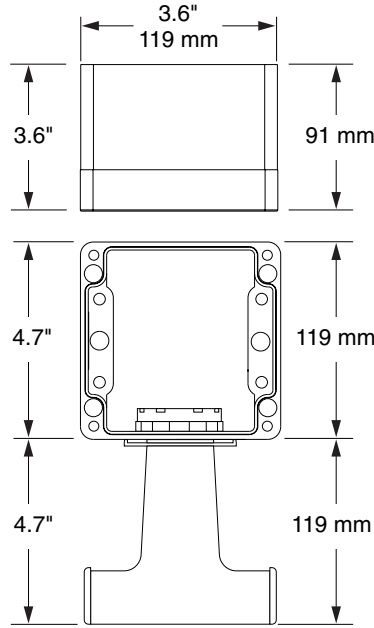

**Raychem product specifications**

Heating cable capability	BTV-CR, BTV-CT, QTVR-CT, XTV-CT, KTV-CT, VPL
Ingress protection	NEMA Type 4X IP66 and IP67
Min. installation temperature	-50°C
Max. pipe temperature	Refer to heating cable specification
Max. operating voltage	277 Vac for FM, CSA 254 Vac for PTB
Max. continuous operating current	50 A heating cable circuit for FM, CSA 40 A heating cable circuit for PTB

**Materials of construction**

Enclosure, lid, and stand	Engineering polymers, black
Lid screws	Stainless steel
Lid gasket	Silicone rubber

**Ordering details**

Part description	T-100
PN (Weight)	447379-000 (2.5 lb /1.2 kg)

**Accessories**

Crimp tool	T-100-CT (not included in the kit, equivalent to Panduit: CT-1570)
PN	954799-000
Spare crimps and insulating tubes	T-100-CRIMP-KIT (spare part only)

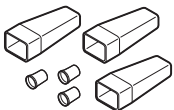

PN	577853-000
Small pipe adaptor	JBM-SPA, required for pipes ≤ 1" (DN 25), D55673-000 (bag of 5 adaptors)